

LV314

ADJUSTABLE IN-GROUND WELL LIGHT

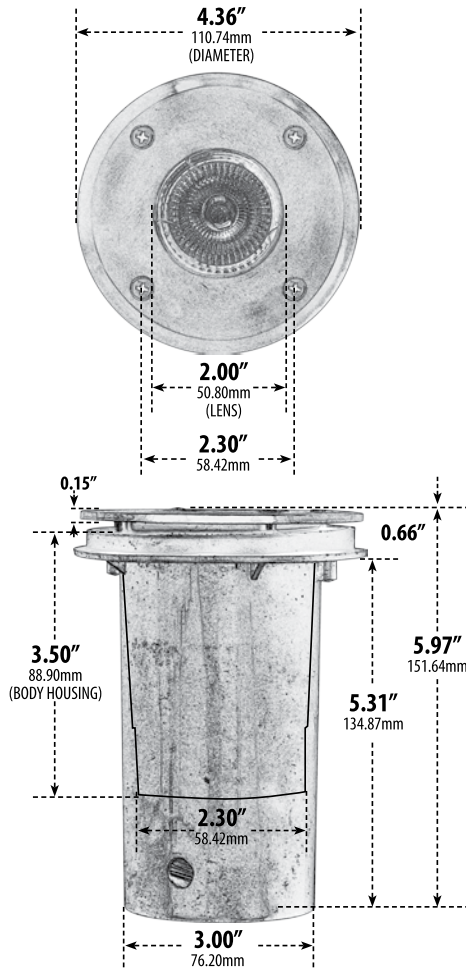

- ▶ **Material:** Stainless Steel Cover, Aluminum Body with PVC Sleeve
- ▶ **Lens:** Clear, Heat Resistant, Tempered Glass
- ▶ **Lamp:** MR16 Bi-Pin Base (35W Maximum) **LED Available in 27K or 65K**

MODEL NUMBER	LAMP TYPE	ILLUMINANT TYPE	WATTS (W)	VOLTS (V)	LAMP(S) INCLUDED?
LV314	MR16	HALOGEN	20	12	YES
LV314-LED3	MR16-LED	LED	3	12	YES
LV314-LED5	MR16-LED	LED	5	12	YES
LV314-LED7	MR16-LED	LED	7	12	YES
LV314-LED4-RGBW	MR16-LED	LED	4	12	YES

Pre-wired with UL Listed Direct Burial Wire/Cable

- ▶ **Installation Type:** Rated for In-Ground Soil and Concrete Applications
- ▶ **Available Finish:** Stainless Steel
- ▶ **RGBW Lamp Requires/Remote:** P-RMT-MR16-LED-4W-MC (sold separately)
- ▶ **ETL Approved**

Overall Dimensions:
5.97"H x 4.36"W x 4.36"D

Weight: 1.40 lbs
Approximate Wire Length: 19"

Box Dimensions:
6.24"H x 4.57"W x 4.59"D

DABMAR
LIGHTING

DABMAR LIGHTING INCORPORATED

320 Graves Ave . Oxnard, CA 93030 . 805.604.9090 . f: 805.604.9050 . www.dabmar.com
4693 19th Street Ct E . Bradenton, FL 34203